



MOULDED SOUND PROJECTOR

CAD20T/EN



This weatherproof soundprojector offers a formally unbeatable combination of design and processing. The specially treated, high-quality housing with stylish shapes and compact dimensions is made of ABS components with integrated UV resistance. The loudspeaker is designed to be easy to mount thanks to the swivel-tilt U-bracket, and is suitable for railway stations, car parks, shopping centers, sports fields, etc. due to its weatherproof design.

EN54-24:2008
0359-CPD-0144
TYPE B



● Standard	Compliant to EN54-24 Compliant to BS 5839:8
● Electrical	
Rated power, Watts	20
Tappings 100 Volt line, Watts	20/10/5/2.5
Transformer Impedance, Ohms 100 Volt	500/1k/2k/4k
Tappings 70.7 Volt line, Watts	10/5/2.5/1.25
Driver impedance, Ohms	8
Effective Frequency Range, Hz (BSEN60268-5)	110-18,000
S.P.L. @ 1 m, 1 Watt, dB, Octave, 100 Hz-10 kHz	92
S.P.L. @ 1 m, Full power, dB, Octave, 100 Hz-10 kHz	105
S.P.L. @ 4 m, 1 Watt, dB, 1/3 Octave, 100 Hz-10 kHz	76
S.P.L. @ 4 m, Full power, dB, 1/3 Octave, 100 Hz-10 kHz	87
Dispersion at 1k/2k Hz, Degrees	189/126 Horizontal 196/120 Vertical
● Environmental	
IP-rating	66
Min/Max amb temp	-25°C to 70°C
Relative humidity	≤95%
● Mechanical	
Dimensions, front & depth, mm	Ø 138x204
Net weight, kg	1.6
Colour (Unless Specified)	White, RAL9016
Material	Low smoke zero Halogen UL-94V0 Plastic with UV inhibitors. Aluminium grill
Mounting	Stainless Steel U bracket
Safety	Ceramic Block Thermal Fuse



ATEIS Europe B.V.
 Celsiusstraat 1, 2652 XN Lansingerland, Netherlands
 Phone +31 (0)10 208 86 90, www.ateis-europe.com, info@ateis-europe.com





PENTON

INSTALLATION GUIDE

CAD20T/EN

EN54-24:2008
0359-CPD-0144
TYPE B

With Transformer:
 100V/70V line

	White wire plus tapping				Black
100V	2.5W	5W	10W	20W	COM
70V	1.25W	2.5W	5W	10W	COM
IMP.(Ω)	4K	2K	1K	500	

Side view
(unit: mm)

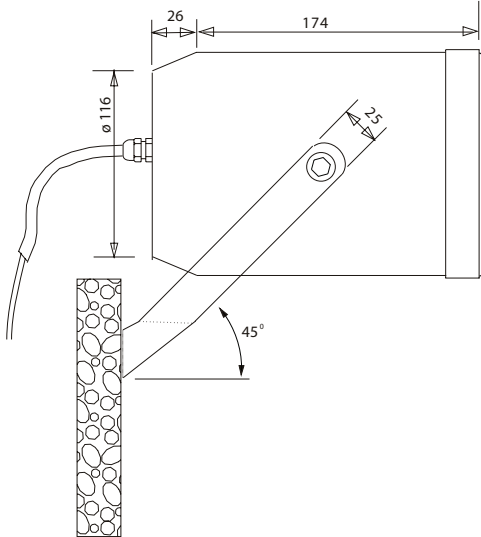

Front view
(unit: mm)

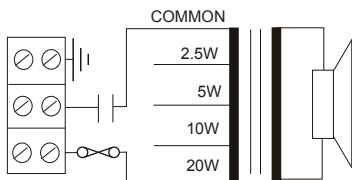
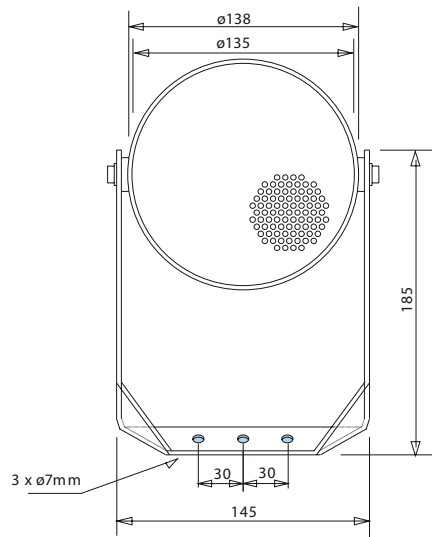

CAD20T/EN

Circuit Diagram

Frequency response

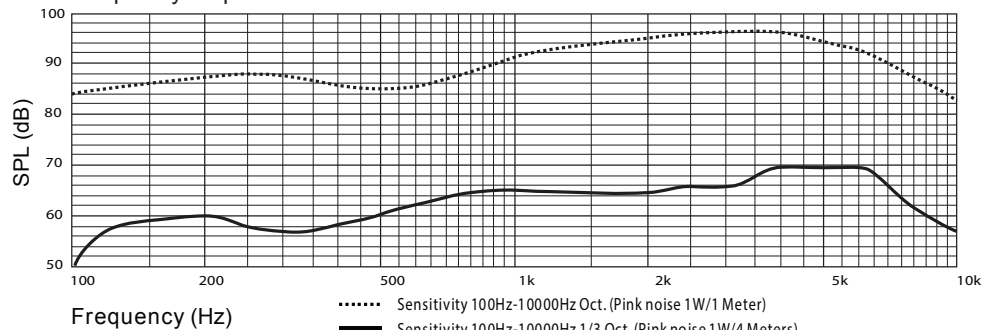

* Active Equalizer Applied: YES
 (EQ Setting: +3.5dB@630Hz, +3.5dB@800Hz, -3.5dB@1250Hz, -3.5dB@1600Hz, -2.5dB@4KHz)



ATEIS Europe B.V.
 Celsiusstraat 1, 2652 XN Lansingerland, Netherlands
 Phone +31 (0)10 208 86 90, www.ateis-europe.com, info@ateis-europe.com



INSTALLATION GUIDE

CAD20T/EN

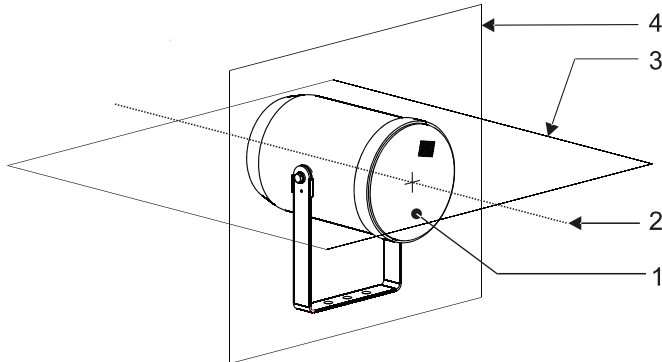

1. Loudspeaker enclosure
2. Reference axis
3. Reference plane
4. Horizontal plane

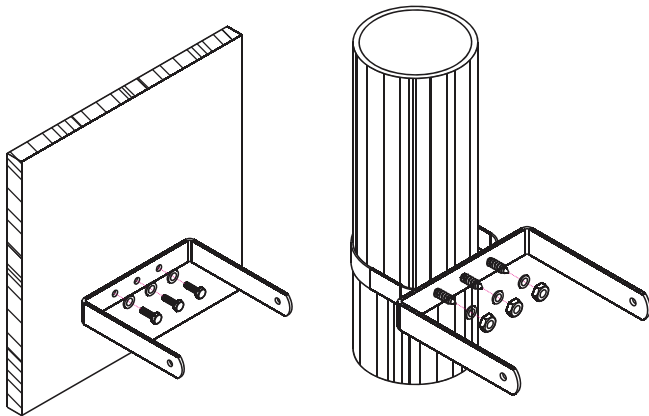

1) Remove the "U" bracket from the speaker. Align the bracket and mark the fixing points. Fix the bracket using suitable fixings (Not supplied).

2) Remove the rear cover. The installation cable can be fitted via suitably rated glands into the 2 x 20 mm gland entries provided.

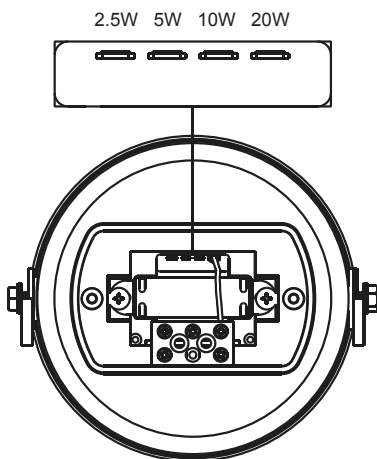
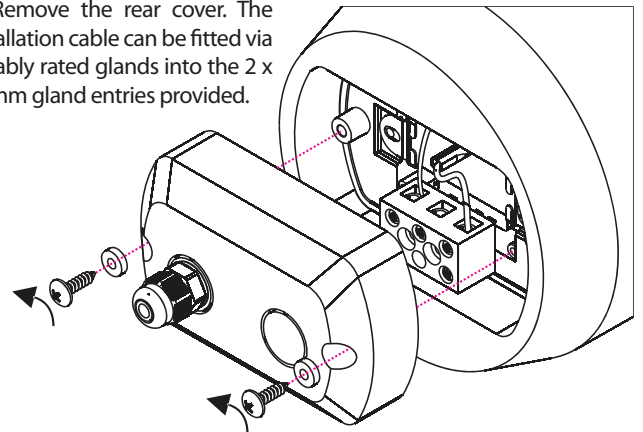

3) The cable can then be terminated into the terminal block fitted to the rear of the speaker. The terminals are suitable to take "loop in"/"loop out" connections up to 2.5 mm per core.

4) Select the desired tapping.
5) Re-fit the rear cover ensuring that the gasket is in place and that the screw fittings are fitted with their rubber washers to ensure the rear cover retains its weatherproof rating.

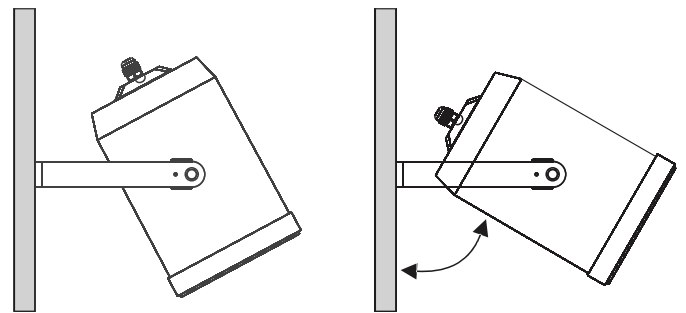

6) Re-fit the speaker to the "U" bracket. Position the speaker to the desired angle then tighten the fixings to secure in place.

Disclaimer: We reserve the right of changes and errors.



ATEiS Europe B.V.
 Celsiusstraat 1, 2652 XN Lansingerland, Netherlands
 Phone +31 (0)10 208 86 90, www.ateis-europe.com, info@ateis-europe.com

