



## ROUND LOUDSPEAKERS

# MWC6T/EN

The round surface-mounted loudspeaker MWC6T/EN in a compact design, with a metal housing and flat non-corrosive grill is suitable due to the excellent acoustic properties and high efficiency for Music and voice transmission.

The ball-protected speaker can be installed with the enclosed mounting bracket and material both on solid ceilings as well as on walls.



**EN54-24:2008**  
**0359-CPD-0151**  
**TYPE A**

● <b>Standard</b>	Compliant to EN54-24 Compliant to BS 5839:8
● <b>Electrical</b>	
Rated power, Watts	6
Tappings 100 volt line, Watts	6/3/1.5/0.75/0.25
Transformer Impedance, Ohms 100V	1.67k/3.33k/6.66k/13.3k/40k
Tappings 70.7 volt line, Watts	3/1.5/0.75/0.25/0.125
Driver impedance, Ohms	8
Effective Frequency Range, Hz (BSEN60268-5)	85-18,500
S.P.L. @ 1m, 1watt, dB, Octave, 100Hz-10kHz	91
S.P.L. @ 1m, Full power, Octave, 100Hz-10kHz	99
S.P.L. @ 4m, 1watt, dB, 1/3 Octave, 100Hz-10kHz	76
S.P.L. @ 4m, Full power, dB, 1/3 Octave, 100Hz-10kHz	81
● <b>Environmental</b>	
IP Rating	21
Min/Max amb temp	-10°C to 55°C
Relative Humidity	≤95%
● <b>Mechanical</b>	
Dimensions, front dia x D, mm	Ø170 x 75
Net weight, kg	1.02
Colour (Unless Specified)	White RAL9016
Material	Steel
Mounting	Screws & Ironing
Safety	Ceramic Block Thermal Fuse



**ATEIS Europe B.V.**  
 Celsiusstraat 1, 2652 XN Lansingerland, Netherlands  
 Phone +31 (0)10 208 86 90, [www.ateis-europe.com](http://www.ateis-europe.com), [info@ateis-europe.com](mailto:info@ateis-europe.com)



# INSTALLATION GUIDE

## MWC6T/EN

EN54-24:2008  
0359-CPD-0151  
TYPE A

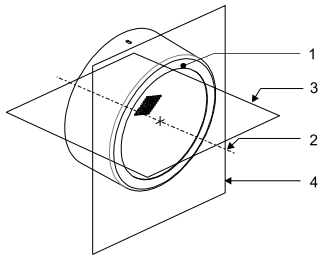
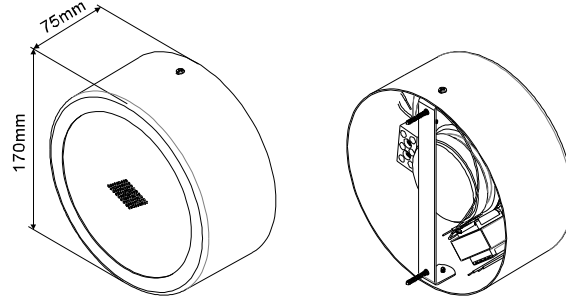

1. Loudspeaker enclosure
2. Reference axis
3. Horizontal plane
4. Reference plane

**With Transformer:  
100V/70V line**

	White wire plus tapping						Black
100V	0.25W	0.75W	1.5W	3W	6W	COM	
70V	0.125W	0.375W	0.75W	1.5W	3W	COM	
IMP (Ω)	40K	13.3K	6.66K	3.33K	1.67K		

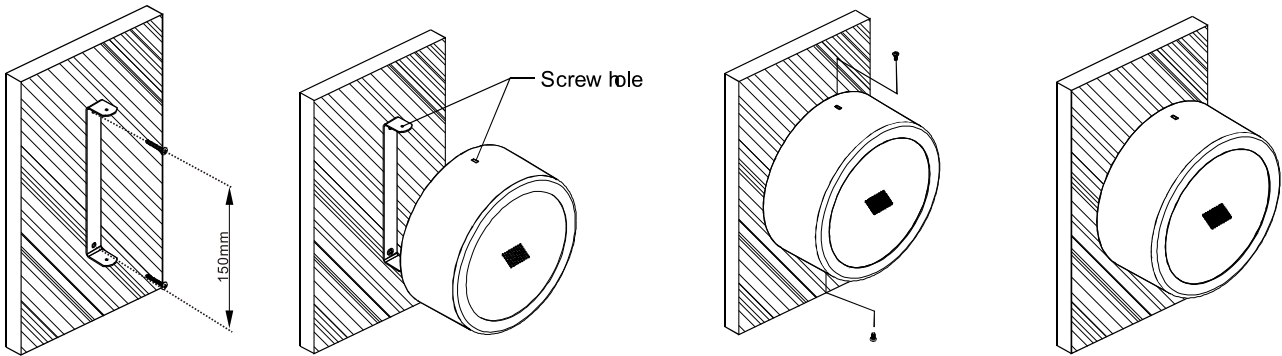

1) Offer the speaker to the wall or ceiling and mark through the mounting holes, as shown on the drawing to the top, the position required for drilling. Drill 2 holes 150mm apart.

2) Cabling can now take place, connect the 100 volt line supply to your required volume as shown on the circuit diagram.

3) After drilling steel bracket and align.

4) Speaker enclosure and slide it over the steel frame using the screws mount.

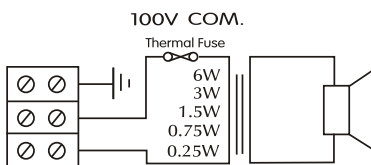

**Circuit Diagram**

### Frequency response

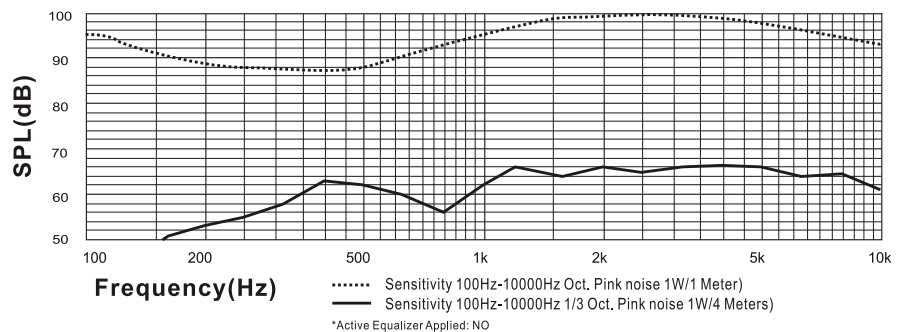

Disclaimer: We reserve the right of changes and errors.



**ATEIS Europe B.V.**  
Celsiusstraat 1, 2652 XN Lansingerland, Netherlands  
Phone +31 (0)10 208 86 90, [www.ateis-europe.com](http://www.ateis-europe.com), [info@ateis-europe.com](mailto:info@ateis-europe.com)

